

# **SCREW** PUMP PROGRAM

Screw Pumps & Systems

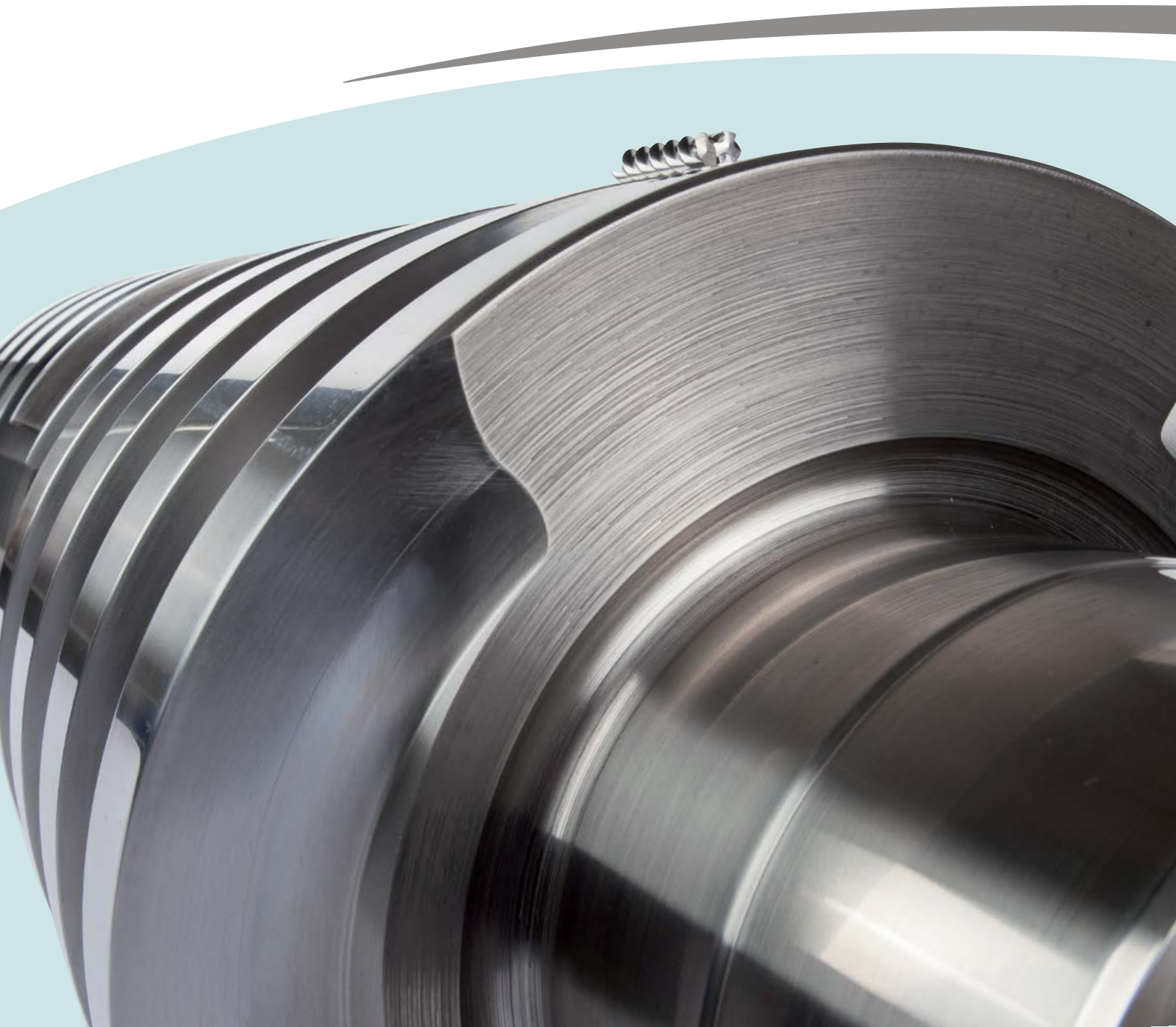





# PUMP TECHNOLOGY

With experience and passion

» We do not only offer pumps, above all, we offer a tailor-made solution for our customers' requirements! «

Leistritz is the first address when it comes to the application of screw pumps. After all, the company, with its headquarters in Nuremberg, is one of the pioneers in the field of screw pumps: 90 years ago, it was Paul Leistritz, who used the twin screw pump for the first time to pump lube oil for steam turbine bearings.

What started out small in 1924 is now a globally active company with more than 300 employees, which has the widest product range in the field of screw pumps. Leistritz Pump Technology has branches in all important markets, such as the USA, China, Singapore, Dubai, India and Italy. Leistritz customers benefit from valuable know-how in various industries and applications.

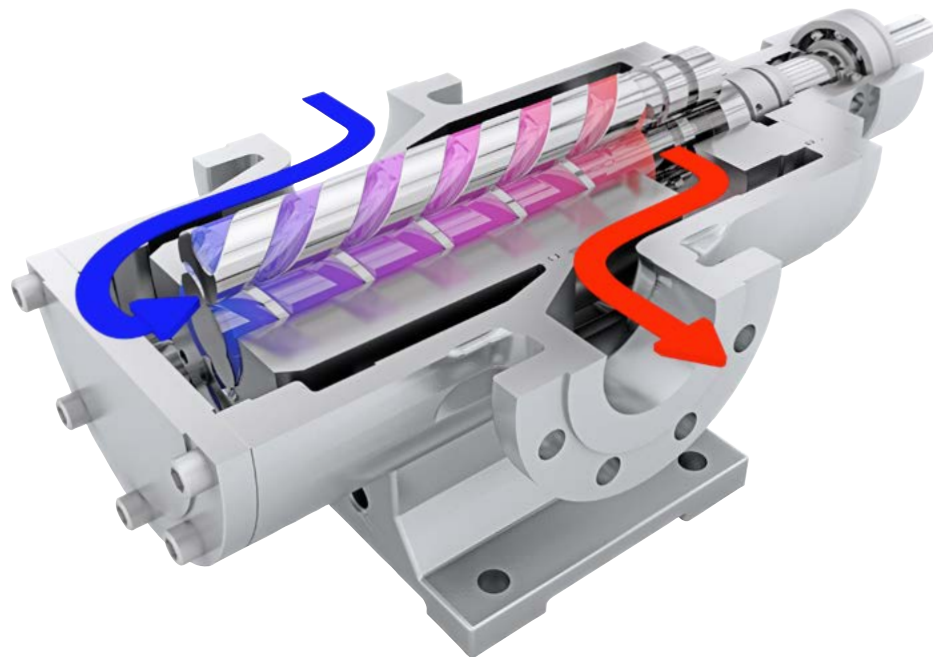

## PUMP FACTS

The intelligent design of the Leistritz screw pumps offers enormous advantages over other pump technologies, like:

- low-pulsation pumping of the fluid
- extremely low vibration and noise
- high flow rates
- pumping a wide range of viscosities
- low-wear operation
- long service life



# PUMP OVERVIEW

For various pressure and flow rates

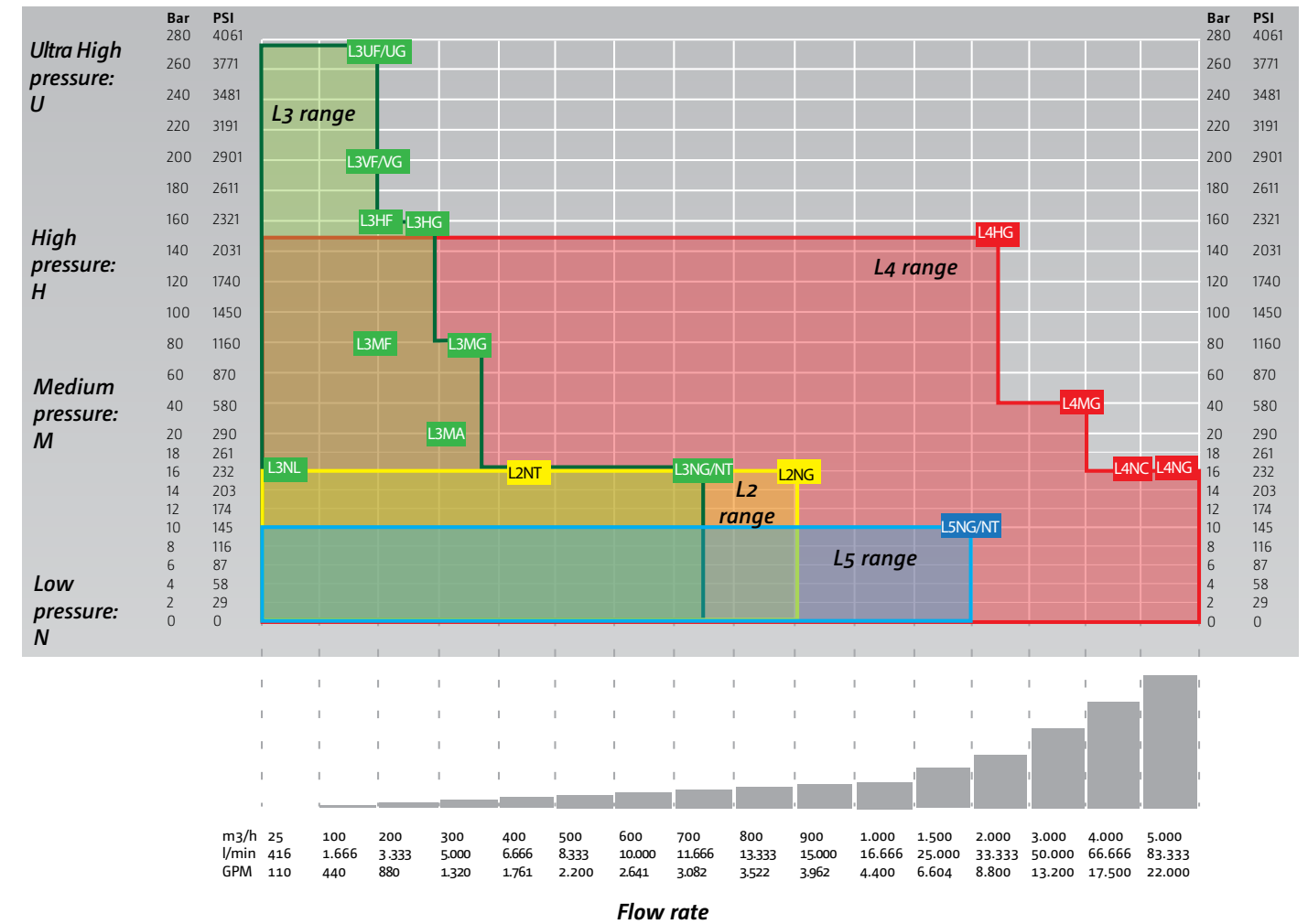

## Leistritz type code

Leistritz (L)

- 2 Spindle (L2)
- 3 Spindle (L3)
- 2 Spindle/double volute (L4)
- 5 Spindle (L5)

- N Low pressure
- M Medium pressure
- H High pressure
- U Ultra high pressure







- G = Pump casing
- F = Flange
- T = Semi submersible
- C = Compact pump
- L = Lube oil pump
- A = API pump



# AT HOME IN MANY INDUSTRIES

Customized solutions for various applications

» Screw pumps by Leistritz can be found in numerous branches of industry. We offer our customers tailor-made solutions for the respective market requirements - ranging from the individual pump to the complete system. «

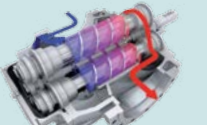
		OIL & GAS	SHIPBUILDING	CHEMICAL	POWER & ENERGY	PETROCHEMICAL
L2 Series		↗	↗	↗	↗	↗
L3N Series		↗	↗	↗	↗	↗
L3M Series		↗	↗	↗	↗	↗
L3H Series		↗	↗		↗	↗
L3V/U Series		↗	↗		↗	↗
L4 Series		↗	↗	↗	↗	↗
L5 Series		↗	↗	↗		↗

		HYDRAULICS	PULP & PAPER	STEEL-PRODUCTION	TEXTILES	PAINTS
L2 Series		↗	↗	↗	↗	↗
L3N Series		↗	↗	↗		
L3M Series		↗	↗	↗	↗	
L3H Series		↗	↗	↗	↗	↗
L3V/U Series		↗		↗		
L4 Series			↗	↗	↗	
L5 Series						

## L2NG/L2NT

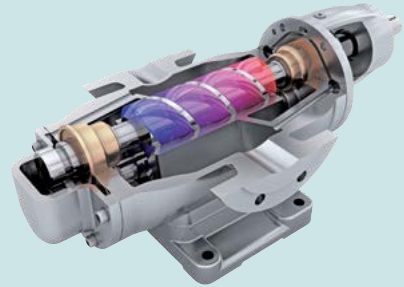

### User advantages

- ↗ Radial slight bearings → long service life
- ↗ High efficiency → low operating costs
- ↗ Axially balanced rotors → no axial forces to bearings
- ↗ Low axial flow velocity → excellent priming
- ↗ Only one shaft seal → easy maintenance, low costs
- ↗ Limited dry running capability → maximized process safety
- ↗ Resistant against aeration → low noise, minimized vibration
- ↗ Availability of sealless design by magnetic drive
- ↗ Semi submersible pump design available

### General use

Leistriz screw pumps of the L2NG/NT series are twin screw, single volute, self-priming, positive displacement pumps for low pressure duty, suitable for transport of slightly abrasive and corrosive, high or low viscous fluids with poor or good lubricity.

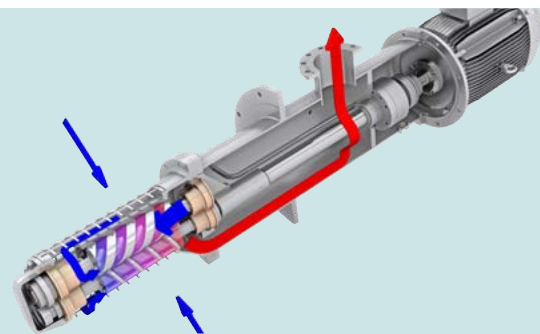

### Performance data

<b>Flow rate:</b>	Max. 900 m <sup>3</sup> /h (3,960 GPM)	0 200 400 600 800 1000 1500 2000 3000 4000 5000
<b>Differential pressure:</b>	Max. 16 bar (232 psi)	0 10 20 30 40 50 100 150 200 250
<b>Viscosity:</b>	Max. 100,000 cSt	0 25000 50000 75000 100000 125000 150000
<b>Pumping temperature:</b>	Max. 280°C (536°F)	0 50 100 150 200 250 300 350

### Applications

	Oil & Gas	Shipbuilding	Chemicals	Petro-chemicals	Power & Energy	General Industry
Blending	↗		↗	↗		
Charging				↗	↗	
Cooling/circulating	↗	↗	↗	↗		↗
Control		↗				↗
Export	↗		↗	↗		
Fuel oil /diesel		↗		↗	↗	↗
Hydraulic		↗			↗	↗
Main lube oil		↗			↗	↗
Seal oil						↗
Stripping	↗	↗	↗			
Transfer	↗	↗	↗	↗	↗	↗
Loading/unloading	↗	↗	↗	↗	↗	

## L3NG/L3NT

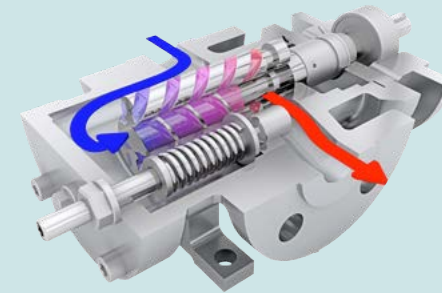

### User advantages

- ↗ High efficiency → low operating costs
- ↗ Axially balanced rotors → no axial forces to bearings
- ↗ Only one shaft seal → easy maintenance, low costs
- ↗ Availability of sealless design by magnetic drive
- ↗ Semi submersible pump design available
- ↗ Resistant against aeration → low noise, minimized vibration
- ↗ Simple design → reasonable price

### General use

Leistriz screw pumps of the L3NG/NT series are triple screw, single volute, self-priming, positive displacement pumps for low pressure duty, suitable for transport of non abrasive lubricating fluids.

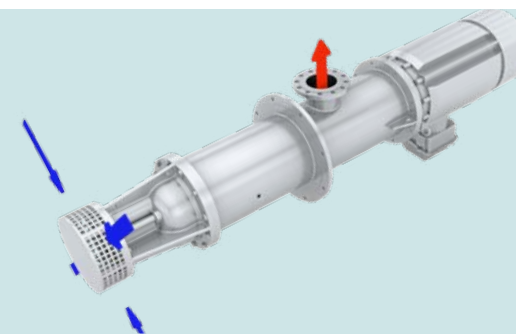

### Performance data

<b>Flow rate:</b>	Max. 700 m <sup>3</sup> /h (3,100 GPM)	0 200 400 600 800 1000 1500 2000 3000 4000 5000
<b>Differential pressure:</b>	Max. 16 bar (232 psi)	0 10 20 30 40 50 100 150 200 250
<b>Viscosity:</b>	Max. 15,000 cSt	0 25000 50000 75000 100000 125000 150000
<b>Pumping temperature:</b>	Max. 180°C (356°F)	0 50 100 150 200 250 300 350

### Applications

	Oil & Gas	Shipbuilding	Chemicals	Petro-chemicals	Power & Energy	General Industry
Blending	↗					
Cooling/circulating	↗	↗				
Control		↗				
Export	↗					
Hydraulic		↗			↗	↗
Main lube oil		↗			↗	
Transfer	↗	↗	↗		↗	↗



## L3MF/L3MG

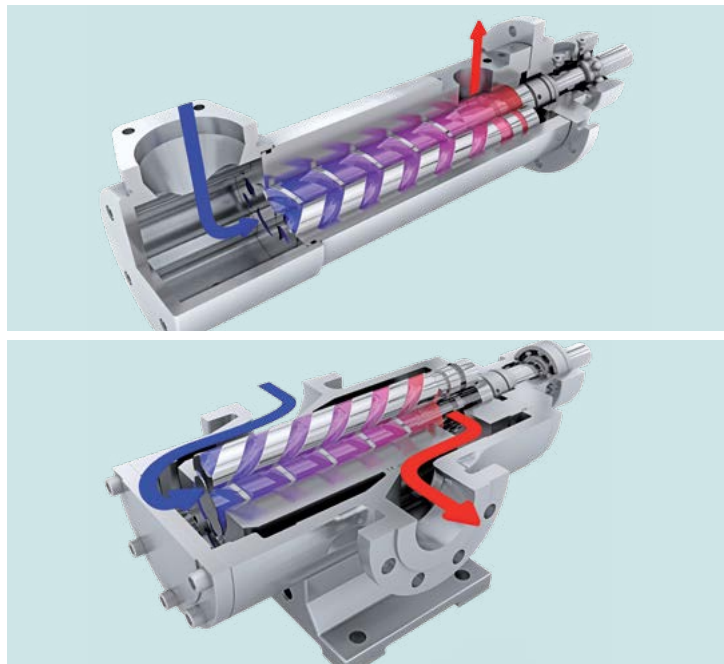

### User advantages

- High efficiency → low operating costs
- Interchangeable casing insert (MG) → easy maintenance
- Axially balanced rotors → no axial forces to bearings
- Only one shaft seal → easy maintenance, low costs
- Availability of sealless design by magnetic drive
- Semi submersible pump design available
- Resistant against aeration → low noise, minimized vibration
- Simple design → reasonable price

### General use

Leistritz screw pumps of the L3MF/MG series are triple screw, single volute, self-priming, positive displacement pumps for medium pressure duty, suitable for transport of non abrasive lubricating fluids.

### Performance data

<b>Flow rate:</b>	MF: Max. 120 m <sup>3</sup> /h (530 GPM) MG: Max. 300 m <sup>3</sup> /h (1,320 GPM)	0 200 400 600 800 1000 1500 2000 3000 4000 5000
<b>Differential pressure:</b>	Max. 80 bar (1,160 psi)	0 10 20 30 40 50 100 150 200 250
<b>Viscosity:</b>	Max. 10,000 cSt	0 25000 50000 75000 100000 125000 150000
<b>Pumping temperature:</b>	Max. 280°C (536°F)	0 50 100 150 200 250 300 350

### Applications

	Oil & Gas	Shipbuilding	Chemicals	Petro-chemicals	Power & Energy	General Industry
Blending	➤		➤			
Control		➤				➤
Charging					➤	
Cooling/circulating	➤	➤	➤	➤		➤
Export	➤		➤			
Foam injection	➤					
Fuel oil/diesel		➤		➤	➤	➤
Hydraulic		➤			➤	➤
Loading/Unloading						
Main lube oil		➤			➤	➤
Transfer	➤	➤	➤	➤	➤	

## L3MA

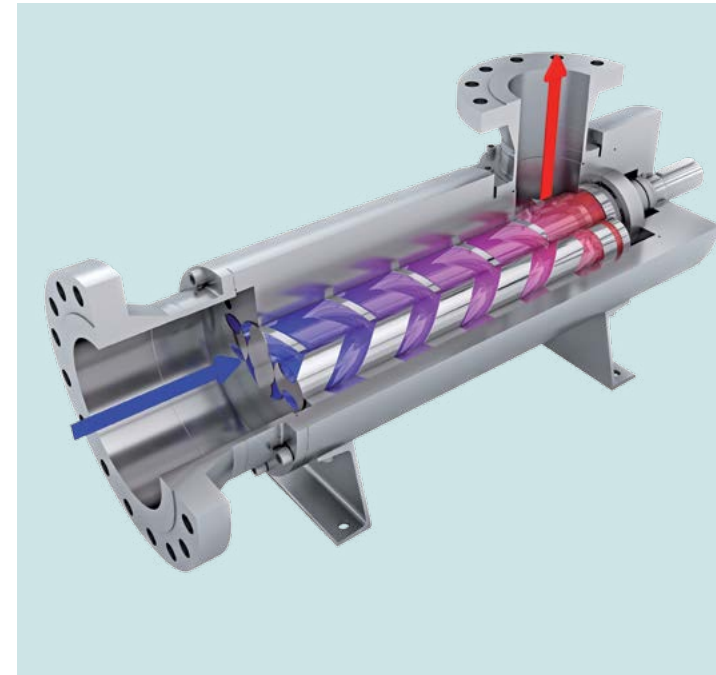

### User advantages

- Class 300 ANSI flange adaptors: designed for the flange loads according to API standards
- Steel liner: Fully complies with the requirements of the API 676 3rd
- Cast iron idlers: for optimum running properties under critical conditions
- Single mechanical seal subjected only to suction pressure, API 682 cartridge seal optional
- No special internal coatings required
- Axial inlet for ease of piping
- Single bearing
- Hydro-dynamically balanced rotors → no thrust bearing required
- Quiet operation → No pulsation

### General use

The new L3MA pump is an API 676 compliant triple screw pump. Due to the use of a new spindle material it is possible to have the spindles run directly in a steel casing.

### Performance data

<b>Flow rate:</b>	Max. 276 m <sup>3</sup> /h (1,215 GPM)	0 200 400 600 800 1000 1500 2000 3000 4000 5000
<b>Differential pressure:</b>	Max. 20 bar (290 psi)	0 10 20 30 40 50 100 150 200 250
<b>Viscosity:</b>	Max. 10,000 cSt	0 25000 50000 75000 100000 125000 150000
<b>Pumping temperature:</b>	Max. 100°C (212°F)	0 50 100 150 200 250 300 350

### Applications

	Oil & Gas / -FPSO	Shipbuilding	Chemicals	Petro-chemicals	Power & Energy	General Industry
Produced water booster	➤					
Forwarding	➤					
Hydraulic					➤	➤
Jacking					➤	
Main lube oil					➤	
Seal oil					➤	
Stripping	➤					
Transfer	➤			➤	➤	➤
Loading/unloading	➤					

## L3HF/L3HG

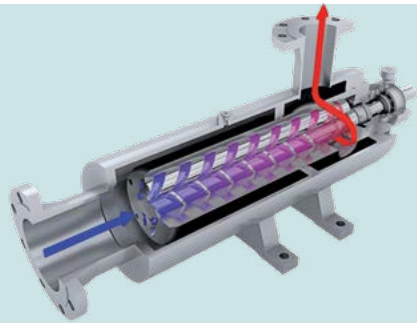
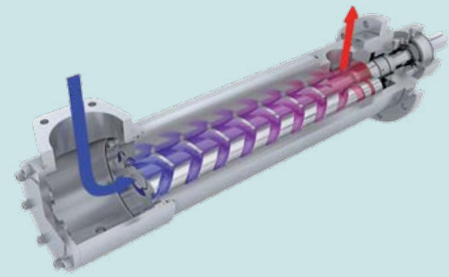

### User advantages

- High efficiency → low operating costs
- Interchangeable casing insert (HG) → easy maintenance
- Axially balanced rotors → no axial forces to bearings
- Only one shaft seal → easy maintenance, low costs
- Availability of sealless design by magnetic drive
- Semi submersible pump design available
- Resistant against aeration → low noise, minimized vibration
- Simple design → reasonable price

### General use

Leistritz screw pumps of the L3HF/HG series are triple screw, single volute, self-priming, positive displacement pumps for high pressure duty, suitable for transport of non abrasive lubricating fluids.

### Performance data

<b>Flow rate:</b>	HF: Max. 120 m <sup>3</sup> /h (530 GPM) HG: Max. 200m <sup>3</sup> /h (880 GPM)	0 200 400 600 800 1000 1500 2000 3000 4000 5000
<b>Differential pressure:</b>	Max. 160 bar (2,350 psi)	0 10 20 30 40 50 100 150 200 250
<b>Viscosity:</b>	Max. 10,000 cSt	0 25000 50000 75000 100000 125000 150000
<b>Pumping temperature:</b>	Max. 280°C (536°F)	0 50 100 150 200 250 300 350

### Applications

	Oil & Gas	Shipbuilding	Chemicals	Petro-chemicals	Power & Energy	General Industry
Blending	➤		➤	➤		
Cooling/circulating	➤			➤		
Export	➤		➤	➤		
Fuel oil injection					➤	➤
Hydraulic		➤			➤	➤
Jacking					➤	➤
Seal oil					➤	➤
Transfer	➤			➤		

## L3V/U

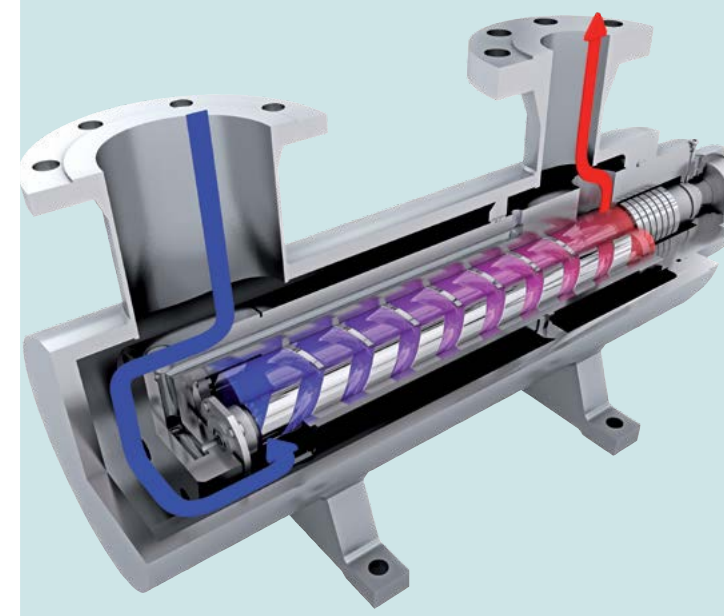

### User advantages

- High efficiency → low operating costs
- Interchangeable casing insert (VG/UG) → easy maintenance
- Wear resistant coatings available
- Axially balanced rotors → no axial forces to bearings
- Only one shaft seal → easy maintenance, low costs
- Availability of sealless design by magnetic drive
- Semi submersible pump design available
- Resistant against aeration → low noise, minimized vibration
- Simple design → reasonable price

### General use

Leistritz screw pumps of the L3VF/UF (VG/UG) series are triple screw single volute, self-priming positive displacement pumps for ultra high pressure duty suitable for transport of slightly abrasive and corrosive, high or low viscous fluids with poor or good lubricity.

### Performance data

<b>Flow rate:</b>	Max. 180 m <sup>3</sup> /h (792 GPM)	0 200 400 600 800 1000 1500 2000 3000 4000 5000
<b>Differential pressure:</b>	U: Max. 280 bar (4,060 psi) V: Max. 200 bar (2,900 psi)	0 10 20 30 40 50 100 150 200 250
<b>Viscosity:</b>	Max. 1,000 cSt	0 25000 50000 75000 100000 125000 150000
<b>Pumping temperature:</b>	Max. 280°C (536°F)	0 50 100 150 200 250 300 350

### Applications

	Oil & Gas	Shipbuilding	Chemicals	Petro-chemicals	Power & Energy	General Industry
Blending	➤		➤	➤		
Booster	➤					
Cooling/circulating	➤			➤		
Export	➤		➤	➤		
Fuel oil injection					➤	➤
Hydraulic		➤			➤	➤
Jacking					➤	➤
Seal oil					➤	➤
Transfer	➤		➤	➤		

## L4NG/MG/HG

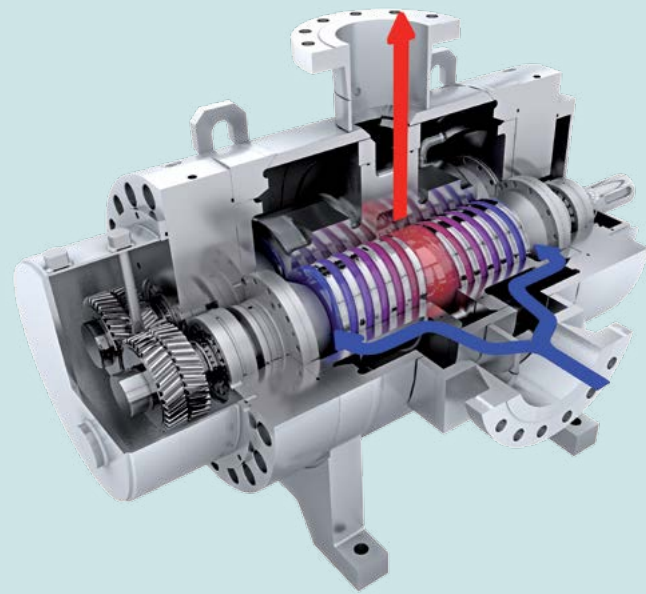

### User advantages

- Rotors (screws and shafts) made out of a single piece of bar stock → limited shaft deflection → Low bearing loads
- Gear designs with helical gear teeth → Reduced noise level → easy maintenance
- Interchangeable liner → easy maintenance, low costs
- Special rotor design available → minimized pulsation → Optimized NPSHR
- Low axial flow velocity → excellent priming
- Axially balanced rotors → no axial forces to bearings
- Suitable for dry running → maximized process safety

### General use

Leistritz screw pumps of the L4 series are twin screw, double volute, self-priming, positive displacement pumps for low, medium and high pressure duty, suitable for transport of abrasive/non abrasive, corrosive/non corrosive, lubricating/non lubricating, high or low viscous fluids.

### Performance data

<b>Flow rate:</b>	Max. 5,000 m <sup>3</sup> /h (22,000 GPM)	0 200 400 600 800 1000 1500 2000 3000 4000 5000
<b>Differential pressure:</b>	Max. 150 bar (2,175 psi)	0 10 20 30 40 50 100 150 200 250
<b>Viscosity:</b>	Max. 150,000 cSt	0 25000 50000 75000 100000 125000 150000
<b>Pumping temperature:</b>	Max. 350°C (662°F)	0 50 100 150 200 250 300 350

### Applications

	Oil & Gas	Shipbuilding	Chemicals	Petro-chemicals	Power & Energy	General Industry
Blending	➤		➤	➤		
Cooling/circulating	➤	➤	➤	➤		
Export	➤		➤	➤		
Pipeline start-up	➤			➤		
Stripping	➤	➤	➤	➤		
Tank cleaning	➤		➤	➤		
Transfer	➤	➤	➤	➤	➤	➤
Loading/unloading	➤	➤	➤	➤	➤	➤

## L4NC

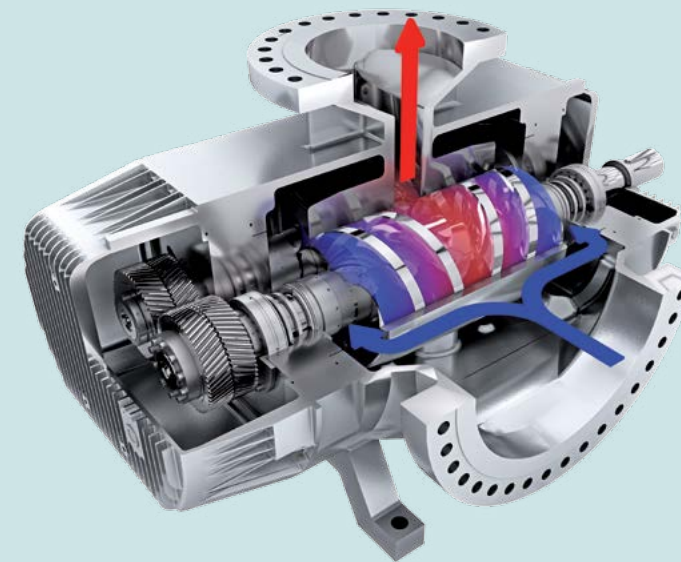

### User advantages

- Economic and slim design for reduced weight
- Pump casing with cast steel (1.0619) and with integrated liner
- ANSI & DIN flanges possible
- Spindles of single bar stock for maximum stiffness and case-hardened steel (1.7139), nitrided for max. hardness
- Side by side arrangement for excellent lubrication capabilities of spindle, bearings and seals
- External double helical gear for efficient power transmission
- Single mechanical seal:
- Component or cartridge design (API conform) possible
- API plan 02/11 and oil quench possible
- Self-aligning roller bearings on DE and NDE side

### General use

The new compact screw pump of the L4NC series are twin screw, double volute, self-priming, positive displacement pumps for low pressure duty. Developed for low capital expenditure (CAPEX) combined with highest efficiency and reliability for optimized operational expenditure (OPEX).

### Performance data

<b>Flow rate:</b>	Max. 5,000 m <sup>3</sup> /h (22,000 GPM)	0 200 400 600 800 1000 1500 2000 3000 4000 5000
<b>Differential pressure:</b>	Max. 20 bar (290 psi)	0 10 20 30 40 50 100 150 200 250
<b>Viscosity:</b>	Max. 10,000 cSt	0 25000 50000 75000 100000 125000 150000
<b>Pumping temperature:</b>	Max. 100°C (189°F)	0 50 100 150 200 250 300 350

### Applications

	Oil & Gas	Shipbuilding	Chemicals	Petro-chemicals	Power & Energy	General Industry
Stripping	➤	➤	➤	➤		
Transfer	➤	➤	➤	➤	➤	➤
Loading/unloading	➤	➤	➤	➤	➤	➤



# L5NG/NT

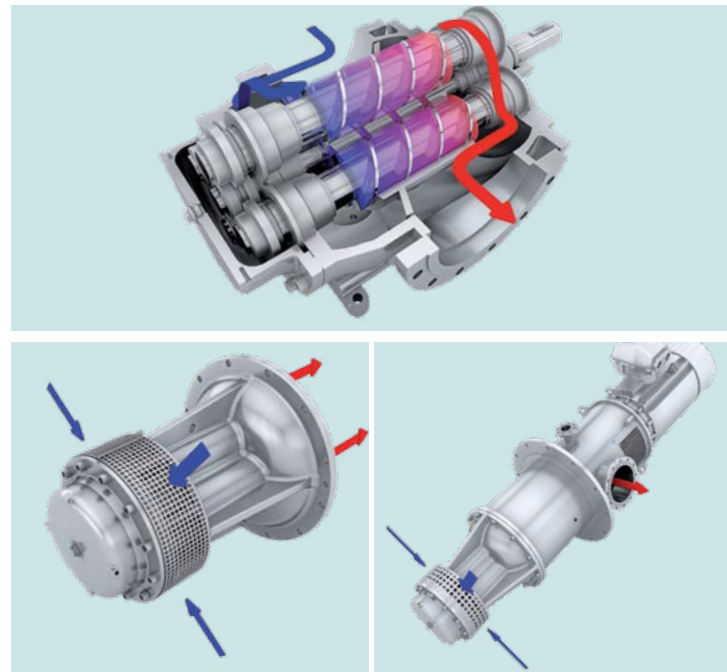

### User advantages

- High efficiency → low operating costs
- Radial slight bearings → long service life
- Axially balanced rotors → no axial forces to bearings
- Low axial flow velocity → excellent priming
- Limited dry running capability → maximized process safety
- Only one shaft seal → easy maintenance, low costs
- Resistant against aeration → low noise, minimized vibration
- Semi submersible pump design available

### General use

Leistriz screw pumps of the L5NG/NT series are five screw, single volute, self-priming, positive displacement pumps for low pressure duty, suitable for transport of slightly abrasive and corrosive, high or low viscous fluids with poor or good lubricity.

### Performance data

<b>Flow rate:</b>	Max. 1,700 m <sup>3</sup> /h (7,500 GPM)	0 200 400 600 800 1000 1500 2000 3000 4000 5000
<b>Differential pressure:</b>	Max. 10 bar (145 psi)	0 10 20 30 40 50 100 150 200 250
<b>Viscosity:</b>	Max. 100,000 cSt	0 25000 50000 75000 100000 125000 150000
<b>Pumping temperature:</b>	Max. 280°C (536°F)	0 50 100 150 200 250 300 350

### Applications

	Oil & Gas	Shipbuilding	Chemicals	Petro-chemicals	Power & Energy	General Industry
Cooling/circulating					➤	
Export	➤	➤	➤	➤		
Main lube oil		➤			➤	
Stripping	➤	➤	➤			
Transfer	➤	➤	➤	➤	➤	➤
Loading/unloading	➤	➤	➤	➤	➤	➤

# PUMP SKIDS



### General use

Besides simple pump skids, consisting of Leistriz screw pumps, drivers and common baseplates, Leistriz supplies complete pump systems, suitable for various duties and applications.

These pump systems include variable speed drives, external lubrication systems, filtration systems, extended pipings with valves, various instrumentation- and control- systems, recirculation systems, cooling facilities, and fire-fighting systems.

Leistriz pump systems are particularly used for crude oil boosting or multiphase application.

### Leistriz System Supply

- Leistriz multiphase pump
- Single or double acting mechanical seals
- Customized liquid management system
- Skid type baseplate
- Electric motors / combustion engines / gas or diesel engines
- Flexible all metal coupling with non-sparking coupling guard
- On-skid instrumentation
- On-skid piping with manually or actuator operated block valves, suction filter, check and pressure relief valve
- Lube and seal oil systems
- Variable speed drives
- PLC, low and medium voltage switch gears, MCC, UPS
- Remote control systems
- Container for installation of the multiphase pump skids and the control equipment





## PUMP TECHNOLOGY

Available for you all over the world

