

DECANTER CENTRIFUGE

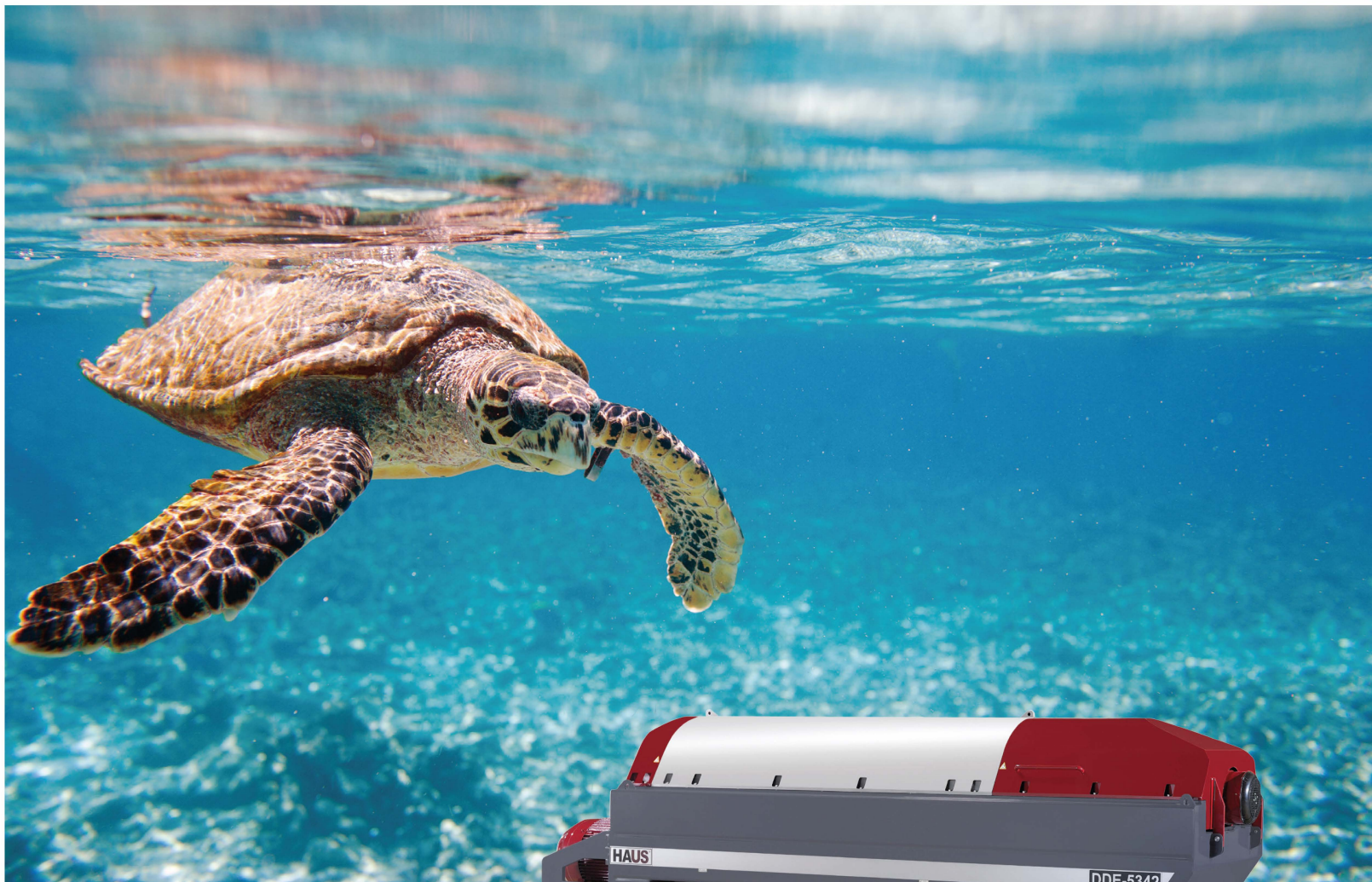

HAUS

CENTRIFUGE TECHNOLOGIES

#BECAUSEWE CARE

hausworld.com       HAUSCentrifugeTechnologies

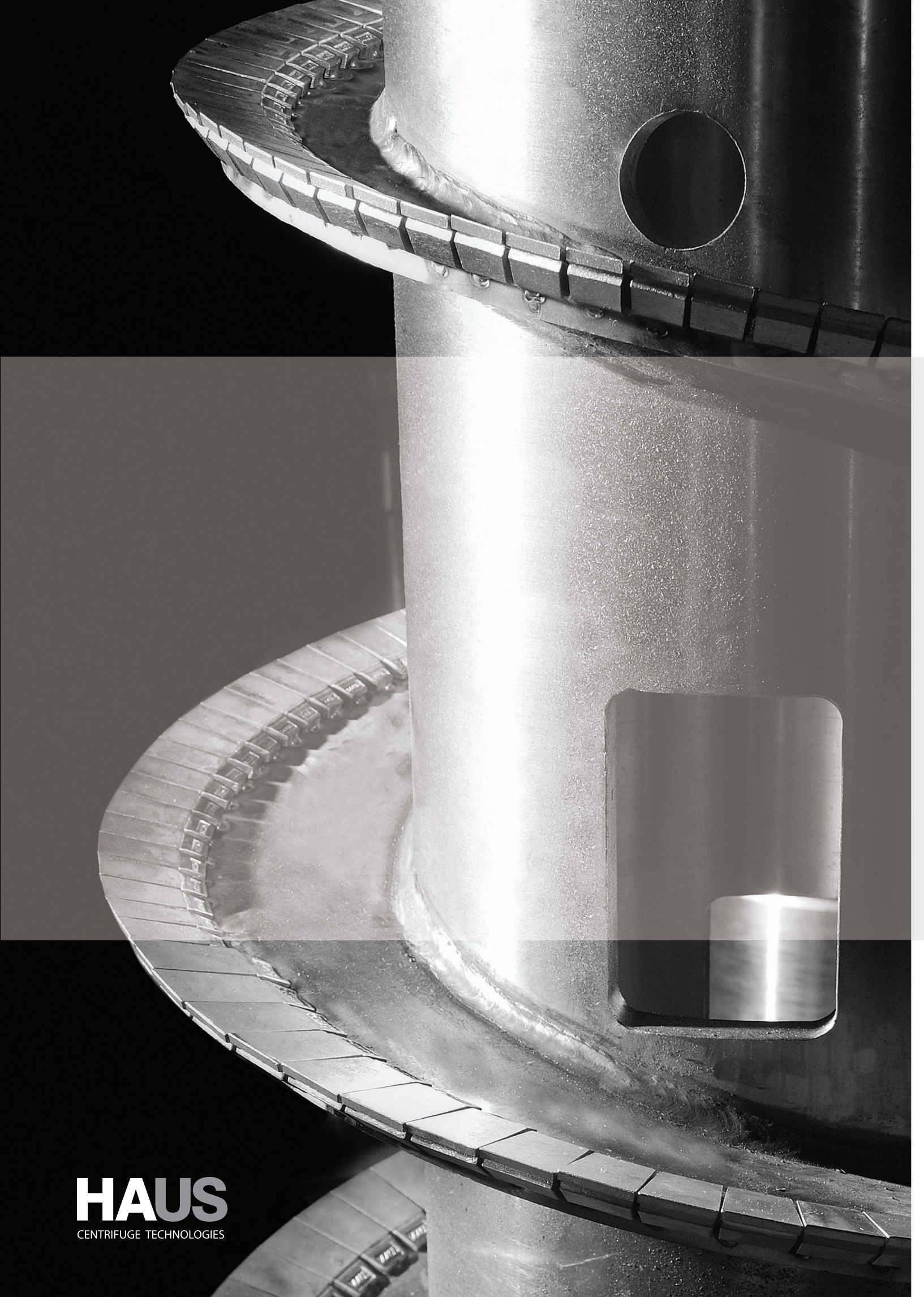

MORE THAN A MACHINE: DECANTER

A centrifuge decanter; consists of a solid cylindrical bowl rotating at high speed, a scroll rotating at the same axis with a slightly different speed, a drive group adjusting the speed difference and the body which carries all the rotating elements.

Liquid and suspended solids are fed along the centre line to a distribution room within the bowl and then accelerated into the bowl by centrifugal force through the feeding point. This centrifugal force then causes the suspended solids to settle and accumulate at the bowl wall.

Sludge cake is discharged by scroll from the conical part meanwhile clarified liquid flows back along the bowl and is discharged through the cylindrical end of the bowl by plates which can adjust the level of clarified liquid.

Centrifuge decanters are applied for separation of liquid mixtures, separation of solid-liquid mixtures, dewatering, thickening, classification of solid-liquid mixtures and extraction of components.

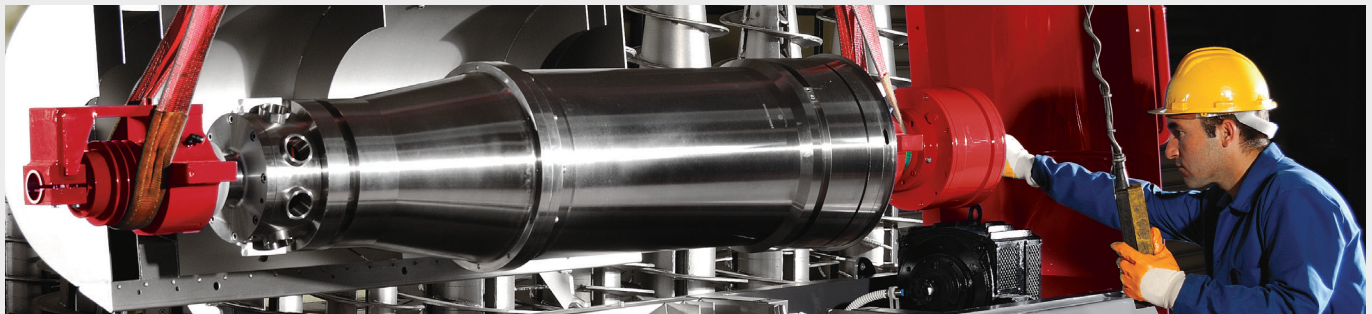

RIGHT ENGINEERING SOLUTIONS

Bowl Group

The bowl is consisted of two parts: cylindrical and conic. Suspension rotates at processing speed along with the bowl and forms a concentric layer at bowl perimeter. Solids available in the suspension accumulate at bowl perimeter with centrifugal force. The length of the cylindrical section of the bowl and the conic section angle are adjusted as per the specific condition of each application.

Scroll Group

Scroll rotates at a slightly different speed than the bowl and conveys the accumulated solids to the end of the conic section of the bowl. If the physical properties of the mixture change, it is possible to support HAUS decanters with a different scroll design or by modifying the existing scroll. Scroll step or single or dual wound scroll configurations are significant design variables.



Material

HAUS uses high quality stainless steel on all surfaces that the product comes in contact with.

Wear Protection

HAUS decanters offer a wide range of wear protection options to be applied on many areas where they are utilized:

- Tungsten Carbide coating with plasma spray
- Ceramic
- Sintered Tungsten Carbide plates
- Polyurethane

Wear protection parts are in-place replaceable in order to save on maintenance costs of applications where high abrasive products are processed.

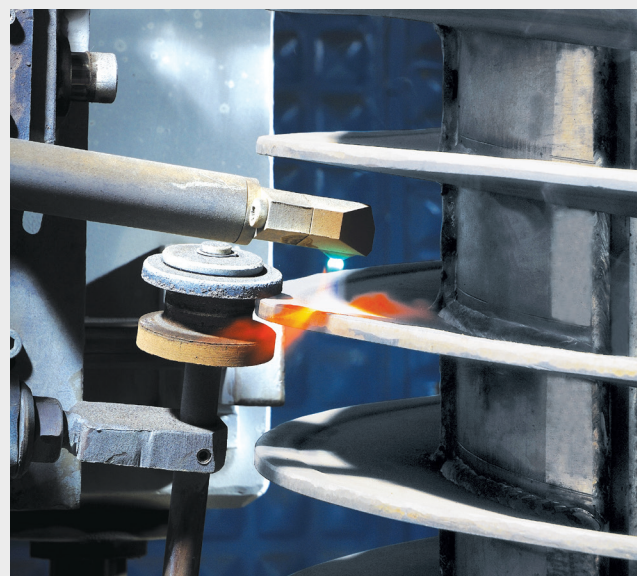



Bearing and Lubrication

Special selection and order of bearings ensure long machinery life and exceptional reliability. Central lubrication system delivers grease or oil to the bearings. The lubrication system changes depending on the operation mode, e.g. sectional or continuous operation mode and depending on the automation level of the whole system.

Leveling Plates

Treated liquids flow over the leveling plates and move forward to the end of the cylindrical section of the bowl of which they'll be delivered to. Easily adjustable sensitive leveling plates enable the pool depth of the bowl to be adjusted precisely. The liquid overflowing from the plates is extracted with gravity from central outlet reservoir.



DRIVE SYSTEMS

HAUS applies advanced engineering techniques to accelerate the decanters to high speeds in safe. One of the most important key factor for decanters is the differential speed. Differential speed determines the amount of moisture hold in the separated solids and the clarity of the centrate. This speed can be adjusted according to the required product characteristics. Drive systems which run to determine this speed are given as below:

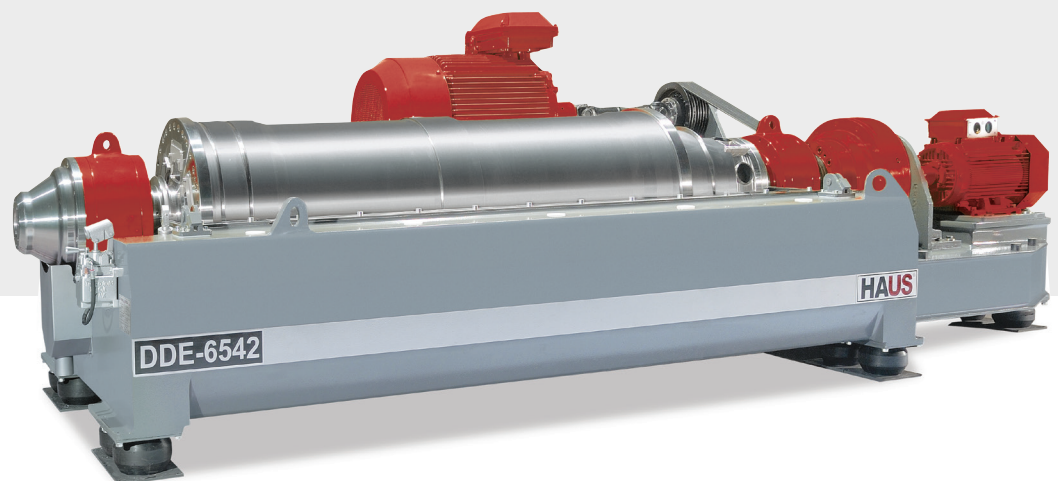



Constant Speed Drive System

This system has low investment costs due to very simple design. This drive system is used when the solids amount is constant, the solids can be conveyed easily and the amount of moisture in the solids is not critical, which means it is not necessary to adjust the differential speed.



Dual Drive System

Dual Drive provides differential speed to be adjusted in a wide range. Second motor drives the gearbox input shaft and makes the differential speed as a function of bowl speed and gearbox rate. Required speed is adjusted when the solids amount is variable noticeably, it is hard to convey the solids and it is important to minimize the amount of water hold in the solids without any human interference. Differential speed is adjusted automatically and very precisely as a function of scroll torque. The system is supported by the software developed by HAUS.

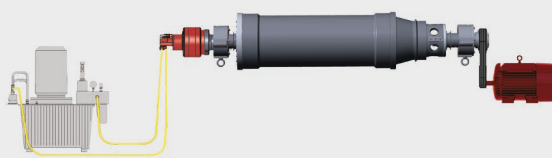

Semi - Driver System with Hydraulic Motor

Instead of a mechanical gear, a rotating hydraulic drive is assembled and this motor is supported with hydraulic regulation. Automatic regulation can be done with no problem because the differential speed is directly proportional with the amount of the oil transmitted. Driver system with hydraulic motor is used when the solids amount is variable, it is hard to convey the solids and it is important to minimize the amount of water left in the solids.



HAUS
CENTRIFUGE TECHNOLOGIES

HAUS
CENTRIFUGE TECHNOLOGIES



Giriş



CONTROL AND AUTOMATION

Automation of HAUS decanters enables fully automatic operation. In addition to the operating variables of the decanter, below functions can be also monitored from main control room:

- Bearing and lubrication temperature
- Bearing and main structure vibration
- Gear torque or the control of differential speed with respect to torque
- Leakage control for isolated systems
- Turbidity control for centrate monitoring
- Feeding pump flow
- Chemical make-up unit control
- Flowmeter
- Conveyor control

ADVANTAGES OF THE DECANTER

Decanter provides the advantage of high efficiency operation compared to traditional separation systems. It was necessary to develop continuing systems in order to reduce the increasing company costs and for the growing industry to be able to adjust itself to the acquired achievements.

Application flexibility

Decanters provide practically high efficiency results under fluctuations at product inlet, differences in process conditions and even at different characteristics of various products. This capability enables reliable and regular operation.

Operational conditions

Appropriate body designs and isolation systems can be applied for steam proof or pressurized processes between 0-8 bars. Tailor made designs and machinery designs are available for cleaning in place (CIP) systems to be used in extremely low and extremely high temperature conditions, explosive atmosphere standards and hygienic environments.

Automation

Operation of the decanter became fully automatic with the use of modern devices and control units. The ability to control whole facility from a central control room enables the decanter to be operated with no personnel.

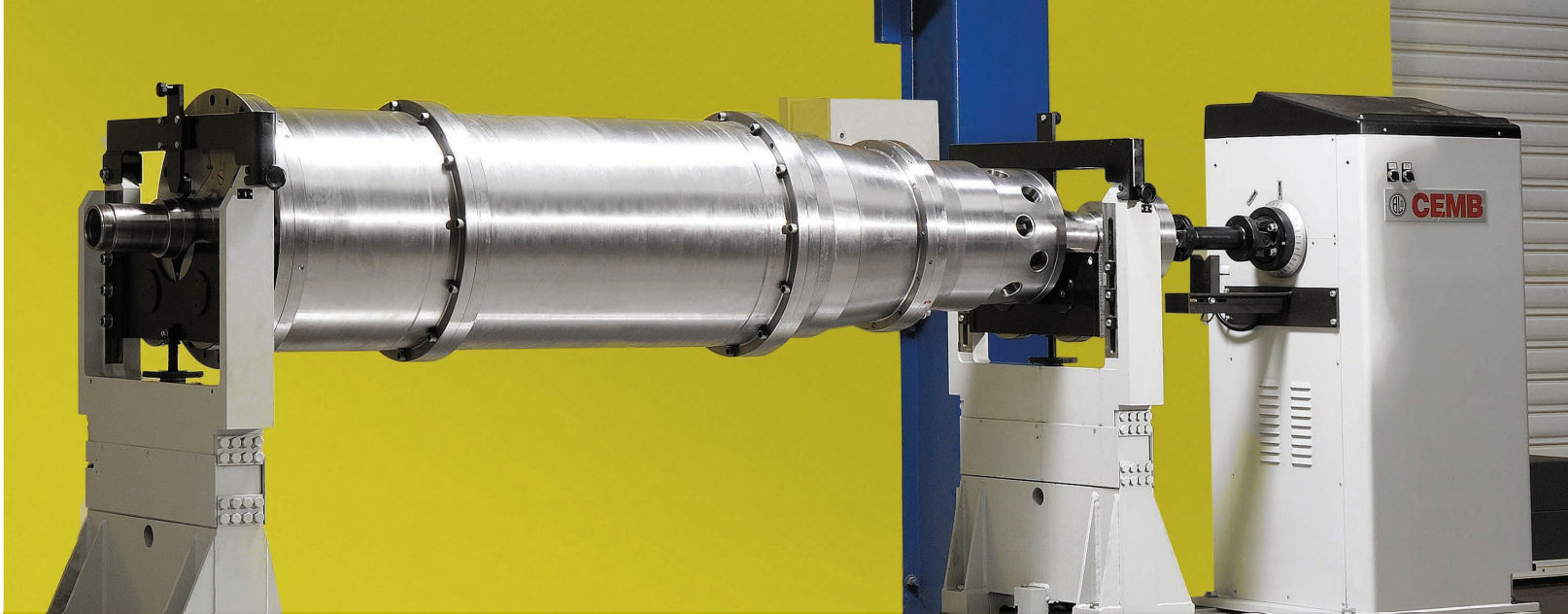

Easy installation

It is possible to install the decanter easily and quickly thanks to its design and all the required functions integrated in single unit. Low vibration levels and active support system of HAUS decanters eliminate complex and expensive base construction. Auxiliary equipments and connections are not needed.

Personnel safety

Closed design of the decanters and the availability of high-tech safety systems ensure high safety for the operator and the maintenance personnel.

Corrosion and wear protection

Process specific materials highly resistant to corrosion and abrasion are used in decanter manufacturing.

Low space requirement

With its excellent design and high processing capacity, the decanter requires a lot less space compared to alternative systems.





EXPERTISE IN NEW AREAS

Decanter centrifuges provide ideal solutions for many different processes and industrial applications. As a result of studies performed jointly with our customers and R&D groups, designs optimizing the whole manufacturing processes are developed and manufactured for various applications.

Besides general directives, there are no routine calculations to determine the equipment for a specific separation process. In many cases, the knowledge and experience of HAUS engineers shall be sought for optimum technical and economic solution. A study to be performed jointly with the laboratory and field tests with mobile units will provide the best solution.

Product samples and the required data related to the process are acquired and assessed at HAUS laboratory and the optimum machinery or system solution is offered. Moreover, onsite tests are performed by our mobile units which can be adjusted for different capacities and processes.

Not only separation characteristics of the product will be analyzed, but also the abrasive and corrosive properties of the inlet products will be analyzed. All these procedures are effected to choose the most appropriate machine for the specific application.



DECANTER APPLICATIONS

Decanters are used in a wide range of industrial areas. Decanters are used in separation of liquid mixtures,

separation of solid-liquid mixtures, dewatering, thickening, classification of solids and extraction of components.

ENVIRONMENTAL APPLICATIONS - E SERIES

- Potable water treatment plants
- Municipal waste water treatment plants
- Industrial waste water treatment plants
- Iron and steel industry treatment plants
- Tannery waste treatment plants
- Power plant treatment plants
- Paper production mills treatment plants
- Slaughterhouse treatment plants
- Mobile units

Thickening Decanter

In this application, decanter is used for sludge thickening. Sludge volume is reduced up to 90% , so the efficient usage of tanks is ensured.

Dewatering Decanter

Separated solids are conveyed along the bowl by the scroll to the conical end of the bowl where the solids are discharged by solid outlet. Solids are pressed at the conical section and the dewatering ratio is increased.





FOOD AND BEVERAGE APPLICATIONS - F SERIES

Beverage Industry

All kind of fruit and vegetable juice, tea and coffee production, beer production, wine production, Spirits production.

Dairy Industry

- Casein
- Lactose

Food Decanters

Decanters developed for this industry are high performance equipments which meet the specific requirements of fruit and vegetable juice production industries in addition to all kinds of food stuff. Besides high product efficiency and controllable product discharge, they are designed suitable for cleaning in place(CIP).

Clarification Decanters

Separation of low density liquid is performed in advanced centrifugal section of the decanter centrifuge.





INDUSTRIAL APPLICATIONS - I SERIES

Oil and Fat Processing

- Clarification of press oil
- Rendering applications
- Biodiesel applications

Oil and Fat Recovery

- Fat and / or animal bone meal
- Blood plasma and / or blood meal
- Edible fats
- Animal origin fat recovery
- Beef broth
- Gelatin
- Fish meal and fish oil extraction
- Coconut Oil
- DAF Sludge
- Technical fats, cocoa butter, olive oil and palm oil.

Oil Fields

- Slop oil recovery
- Tank bottom oil recovery
- Oil recovery from lagoons

Drilling Industry

- Sludge control in tunnel works
- Barite recovery
- Dewatering

Starch Industry

- Corn starch
- Wheat starch
- Starch extraction
- Potato starch and protein
- Ethanol production
- Tapioca starch

Chemistry and Pharmaceutical Industry

- Pharmaceutical raw material production
- Chemical raw material clarification
- Chemical raw material classification



HAUS

CENTRIFUGE TECHNOLOGIES



2-Phase Decanter

This technology is developed for applications requiring solid-liquid separation. Separating two liquids in a single equipment has simplified many processes.

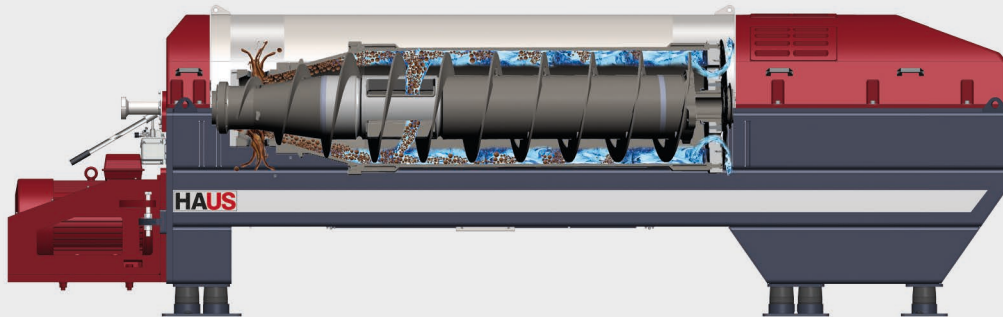

3-Phase Decanter

This technology is developed for applications requiring solid-liquid-liquid separation.

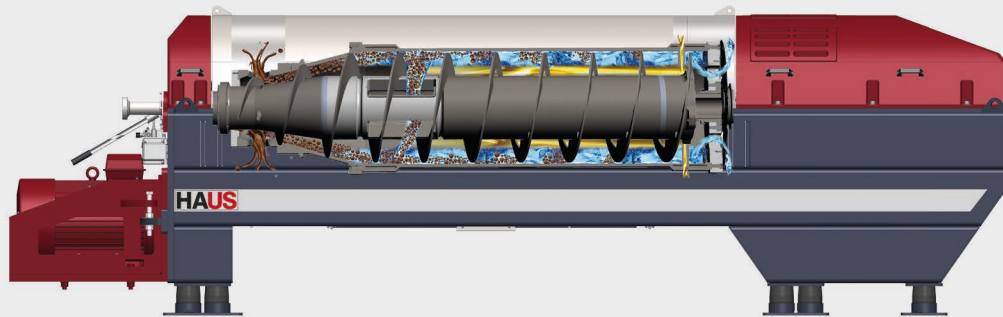



Certification and Testing

Modern communication techniques provide correct planning and reliable delivery periods. Comprehensive quality control is in the nature of HAUS. The company has ISO 9001:2008 and TSEK certificates. The safety precautions of machines in work places and their compatibility with CE directives are approved by TÜV. Each HAUS decanter is tested during material processing prior to delivery in order to guarantee smooth operation. Moreover, all decanters are tested at test bay before delivery.

Engineering

Wide range of options for the components (materials, surface hardening, drive systems, isolations, and screw geometry, feeding and discharge systems) of the systems or new designs for a new separation application are provided when necessary.

Mechanical Design

Modern CAD design provides fast revisions and high quality designs. Basic rotor dynamics and basic body dynamics that have key roles for smooth and quiet operation are analyzed by HAUS using mode based analysis techniques and advanced FEM techniques specially developed for decanter centrifuge designs.

Start-up and Commissioning

HAUS service unit gained experience for long years in all types of decanters. HAUS engineers and technicians superintend in all stages of commissioning and start up, operation and adjustment of the decanter for the most appropriate operation and make necessary interventions.

Production Resources

HAUS manufactures in a wide range of machinery at different capacities. The capacity range is from 1 m³/h to 250 m³/h.

Customer Service

HAUS employs expert engineers, project managers, production, installation and resource experts as well as field service technical workers in order to fulfill the needs of its customers. HAUS works with end-users, contractors or engineering companies in order to solve operational issues in complex flow charts.

Spare Parts and Service

HAUS ensures problem-free parts replacement and long lasting operation in original spare parts supply with accurate design tolerances and materials. If requested, mechanical condition and operational performance of machinery are performed onsite for customers and by service agreements. Scheduled maintenance and replacements as per conditions can reduce downtimes significantly and increase production capacity.



PRODUCT GROUPS AND MODELS

Model	2342
Length (mm)	2362
Width (mm)	827
Height (mm)	974
Weight (kN)	8,4



Model	3542
Length (mm)	3585
Width (mm)	830
Height (mm)	1034
Weight (kN)	20,6



Model	3532
Length (mm)	3204
Width (mm)	830
Height (mm)	1034
Weight (kN)	17,6



Model	4042
Length (mm)	3583
Width (mm)	1002
Height (mm)	1310
Weight (kN)	23



HAUS offers its customers a wide range of products. HAUS manufactures decanters of diameters from 238 mm to 820 mm in different lengths and configurations. It is possible to process products from 1 m³/h up to 250 m³/h with these decanters.

Model	4742
Length (mm)	4882
Width (mm)	1225
Height (mm)	1300
Weight (kN)	44



Model	6542
Length (mm)	5712
Width (mm)	2131
Height (mm)	1579
Weight (kN)	95

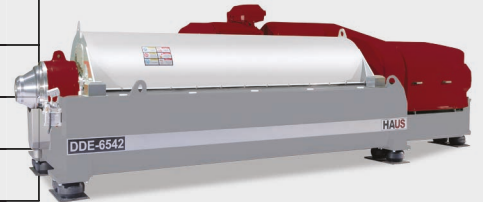

Model	5342
Length (mm)	5406
Width (mm)	1671
Height (mm)	1583
Weight (kN)	65



Model	8242
Length (mm)	5780
Width (mm)	2421
Height (mm)	1749
Weight (kN)	155

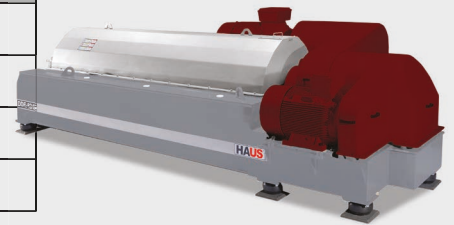

* HAUS, reserves the right to modify the specifications herein without prior notice.

HAUS reserves the right to modify the specifications here in without prior notice.



- **FACTORY**
ATA OSB Mahallesi
Denizli Bulvarı No:110
Aydın-TURKEY
T: 0 256 231 04 81
F: 0 256 231 04 83
- **HAUS İstanbul**
Şerifali Mahallesi
Emin Sokak No. 5/6 34775
Ümraniye-İstanbul-TURKEY
T: 0 216 576 06 27
F: 0 216 576 06 37
- **HAUS Europe**
Ridderkerk-NETHERLANDS
T: +31 85 48 91 190
info@hauseurope.com
- **HAUS Med**
Bari-ITALY
T: +393407266058
info@hausitaly.it
- **HAUS Iberica**
Cordoba-SPAIN
info@hausiberica.es
- **HAUS Sea**
Kuala Lumpur - MALAYSIA
T: +60 17 267 8116
info@haussea.my
- **HAUS SA**
New Delhi, INDIA
T: +91 11 6654 4078

HAUS
CENTRIFUGE TECHNOLOGIES

#BECAUSEWECARE

hausworld.com [f](#) [t](#) [l](#) [i](#) [o](#) [g](#) #HAUSCentrifugeTechnologies